

REVISION RECORD				
REV	ECO	DESCRIPTION	DRFT	CHKD

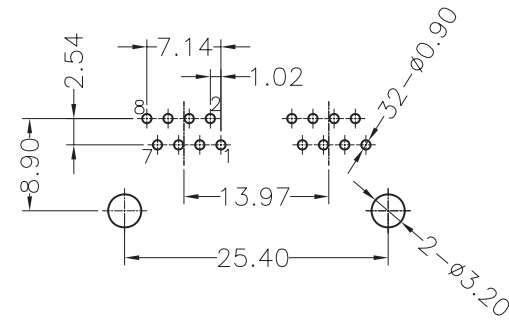
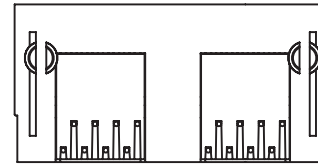
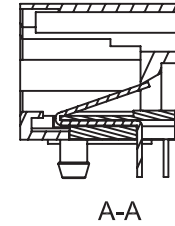
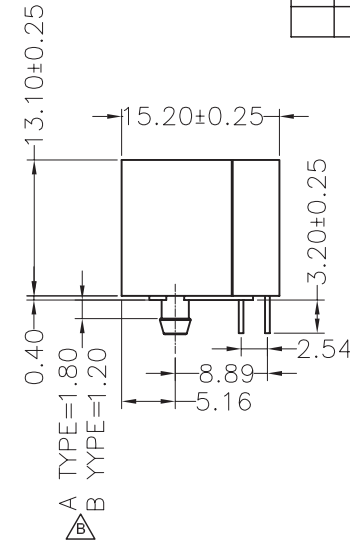
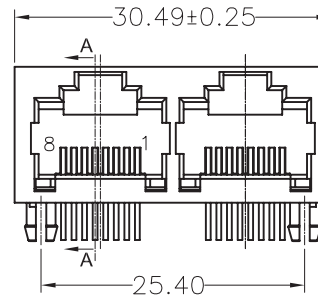

PC Board Layout

NOTES:

MATERIAL:

- 1.HOUSING MATERIAL :GLASS FILLED POLYESTER(UL94V-0).
- 2.CONTACT MATERIAL :PHOSPHOR BRONZE $\phi 0.46\text{mm}$ (C5100).
- 3.PLATING :GOLD PLATING OVER NICKEL.

ELECTRICAL:

- 1.VOLTAGE RATING :125 VAC RMS.
- 2.CURRENT RATING :1.5 AMP.
- 3.CONTACT RESISTANCE :50 MILLIOHMS MAX.
- 4.INSULATION RESISTANCE :500 MEGOHMS MIN @ 500V DC.
- 5.DIELECTRIC WITHSTANDING RESISTANCE :1000V AC RMS 50Hz. 1MIN.

MECHANICAL:

- 1.DURRABILITY :750 CYCLES MIN.
- 2.PCB RETENTION PRE-SOLDER :1 LB MIN.

ENVIRONMENTAL:

- 1.STORAGE : -40°C TO $+85^{\circ}\text{C}$.
 2. OPERATION : 0°C TO 70°C .
- MATES WITH MODULAR PLUG CONFORMING TO FCC PART 68,SUBPART F.

DETACHED LISTS	← MM (INCH) →		设计 peilei	日期 09.08.07	Coorle 库乐科技	
	一般公差栏		审核 jindelian	日期 10.01.26		
	MM	±	批准 Oscar	日期 11.06.16	系列	名称
	.0 ± 0.20	±	材料:		56 1*2 8P8C	
	.00 ± 0.15	±	数量:			
	.000 ± 0.075	±	表面处理:		图号:	A3
角度 ± 0.01°		比例: 1:1		料号: 请查看注释	版本 A	
第三角视图				不按比例	共 X 页 第 Y 页	